

TECHNICAL STANDARDS & SAFETY AUTHORITY
345 CARLINGVIEW DRIVE
TORONTO ON M9W 6N9

Date: March 12, 2020
Account #: 35231
Journal #: 75299

Attn: CECYLIA GARBACZ

Re: Application for Design Registration

The design, as detailed in your, CRN#0A22161.5, for a Fitting is accepted for registration as follows:

Registered To: SWAGELOK COMPANY **CRN:** 0A22161.51

Drawing #: Scope of Registration

Drawing Revision: N/A

Conditions Of Registration:

This design was registered based on a technical review performed by the province of initial registration in accordance with the Association of Chief Inspectors policy on reciprocal recognition of design review.

Scope of Registration: Attachment A and B- VCO 0 RING FACE SEAL FITTINGS

Reviewer's Notes:

As required by CSA B51 4.2.1, this registration expires on 10-Feb-2030. This CRN is valid until the expiry date as long as the Manufacturer maintains a valid quality control program verified by an acceptable third-party agency until that date. Should the certification of the quality control program lapse before the expiry date, this registration shall become void. Any additional conditions of registration stated in TSSA CRN# 0A22161.5 registration shall apply to BC registration.

Contact me if you have any questions. The invoice for registration will be forwarded under separate cover.

Janina Mihailescu

janina.mihailescu@technicalsaftybc.ca
Design Administration

cc:



Technical Standards and Safety Authority
 345 Carlingview Drive
 Toronto, Ontario M9W 6N9
 www.tssa.org

Show facsimile of manufacturer's logo or trademark, as it will appear on the fitting, in the space below

Swagelok

STATUTORY DECLARATION Registration of Fittings

I, Joel Feldman, Vice President of Engineering
(Name and Position, e.g. President, Plant Manager, Chief Engineer)

of Swagelok Company
(Name of Manufacturer)

Located at 29500 Solon Road, Solon, Ohio 44139 USA (Plant Address) (440) 248-4600 (Telephone No.) (440) 349-5970 (Fax No.)

do solemnly declare that the fittings listed hereunder, which are subject to the **Technical Standards and Safety Act**, Boilers and Pressure Vessels Regulation, comply with all of the requirements of ASME B31.1 for unlisted components, and ASME B31.3 for unlisted components
(Title of recognized North American Standard)
 which specifies the dimensions, materials of construction, pressure/temperature ratings, identification marking the fittings and service;

or are not covered by the provisions of a recognized North American standard and are therefore manufactured to comply with _____ as supported by the attached data which identifies the dimensions, material of construction, pressure/temperature ratings and the basis for such ratings, the marking of the fitting for identification and service.

I further declare that the manufacture of these fittings is controlled by a quality system meeting the requirements of ISO 9001:2015 which has been verified by the following authority, BSI

The items covered by this declaration, for which I seek registration, are category A Fitting _____ type fittings. In support of this application, the following information and/or test data are attached as follows:
ISO 9001:2015 Certificate, Attachment A, Attachment B, Catalog Information and other Support Documents
(drawings, calculations, test reports, etc.)

Declared before me at Solon in the state of Ohio
 the 25th day of Nov AD 2019.

Commissioner for Oaths:
Brenda Hammel
(Printed name)
Brenda Hammel
(Signature)

Joel C. Feldman
(Signature of Declarer)

FOR OFFICE USE ONLY

To the best of my knowledge and belief, the application meets the requirements of the **Technical Standards and Safety Act**, Boilers and Pressure Vessels Regulation, and CSA Standard B51 and is accepted for registration in Category A.

Technical Standards and Safety Authority
 Boilers and Pressure Vessels Safety Program

REGISTERED

C.R.N.: 0A22161.5

Signed: [Signature]

Date: Feb 10, 2020

CRN: 0A22161.5

Registered by: [Signature]

Dated: Feb. 10, 2020

NOTE: This registration expires on: Feb 10, 2030

*Information provided in this application is releasable under the Freedom of Information and Privacy Protection Act and may be disclosed upon request.

See attachment A and B for scope of registration

Attachment B: Scope of Registration for VCO O-Ring Face Seal Fittings (Category A)

This document represents the scope of Swagelok's VCO O-Ring Gasket Face Seal Fittings covered by this submission for CRN approval in compliance with the requirements of ASME B31.1-2018 "Power Piping" as unlisted components per Section 104.7.2 and ASME B31.3-2018 "Process Piping" as unlisted components per Section 304.7.2.



Summary Table

Product Series (Size)	Pressure Retaining Materials	Pressure Retaining Components	End Connections and Sizes	Maximum Rated Pressure (psig)		Design Code of Construction
				At 100°F	At Max Temp*	
-2 VCO (1/8")	316 SS (ASTM A479, ASTM A276) for straight fittings and glands F316 SS (ASTM A182) for shaped fittings	Gland, Body	Tube Socket Weld 1/8"	12,600	8,120 @ 550°F	ASME B31.1 (Unlisted Components) and ASME B31.3 (Unlisted Components)
-4 VCO (1/4")			Gland, Body	Tube Socket Weld 1/4"	6,800	
		Reducing Tube Socket Weld 1/8"		12,600	8,120 @ 550°F	
		Male Tube Weld 1/8", 1/4"		11,200	7,220 @ 550°F	
		Automatic Tube Weld 1/4"		5,100	2,700 @ 550°F	
		Swagelok Tube Fitting 1/8", 1/4"		10,900-10,200	8,120 @ 550°F	
		Male SAE/MS 7/16-20, 9/16-18		4,500	4,500 @ 400°F	
		Male NPT 1/8", 1/4"		10,000-8,000	6,900-5,520 @ 450°F with sealant	
		Female NPT 1/8", 1/4"		8,400-6,600	5,790-4,550 @ 450°F with sealant	
-6 VCO (3/8")		Gland, Body	Tube Socket Weld 3/8"	8,100	5,220 @ 550°F	
-8 VCO (1/2")	316 SS (ASTM A479, ASTM A276) for straight fittings and glands	Gland, Body	Tube Socket Weld 1/2"	3,000	1,935 @ 550°F	
			Reducing Tube Socket Weld 1/4"	10,700	6,900 @ 550°F	
			Male Tube Weld 1/4", 3/8", 1/2"	11,100-7,500	7,160-4,830 @ 550°F	
			Automatic Tube Weld 3/8", 1/2"	3,500-3,300	1,850-1,750 @ 550°F	
			Swagelok Tube Fitting 3/8", 1/2"	7,500-6,700	6,600-4,830 @ 550°F	
			Male NPT 3/8", 1/2"	10,000-7,800	6,900-5,310 @ 450°F with sealant	
			Female NPT 3/8", 1/2"	6,600-4,900	4,450-3,380 @ 450°F with sealant	
	F316 SS (ASTM A182) for shaped fittings	Body	Male NPT 3/8", 1/2"	7,800 - 7,700 @ 100°F	5,380 - 5,310 @ 450°F with sealant	
			Swagelok Tube Fitting 3/8", 1/2"	7,500 - 6,700 @ 100°F	6,600 - 4,830 @ 550°F	
			Male SAE/MS 9/16-18, 3/4-16	3,600	3,600 @ 400°F	

Swagelok

Canadian Registration Number Submittal
 Category A: Swagelok VCO® O-Ring Face Seal Fittings

Date: January 20, 2020
 Page 2 of 4

Summary Table (cont'd)

Product Series (Size)	Pressure Retaining Materials	Pressure Retaining Components	End Connections and Sizes	Maximum Rated Pressure (psig)		Design Code of Construction
				At 100°F	At Max Temp*	
-12 VCO (3/4")	316 SS (ASTM A479, ASTM A276) for straight fittings and glands	Gland, Body	Tube Socket Weld 3/4"	3,700	2,385 @ 550°F	ASME B31.1 (Unlisted Components) and ASME B31.3 (Unlisted Components)
			Automatic Tube Weld 3/4"	2,200	1,160 @ 550°F	
			Swagelok Tube Fitting 3/4"	5,800	5,100 @ 550°F	
			Male NPT 3/4"	7,300	6,420 @ 450°F with sealant	
			Female NPT 3/4"	4,600	3,170 @ 450°F with sealant	
			Male SAE/MS 1-1/16-12	3,800	3,800 @ 400°F	
	F316 SS (ASTM A182) for shaped fittings	Body	Male NPT 3/4"	5,800	5,030 @ 450°F with sealant	
			Swagelok Tube Fitting 3/4"	5,800	5,100 @ 550°F	
			Male SAE/MS 1-1/16-12	2,900	2,900 @ 400°F	
-16 VCO (1")	316 SS (ASTM A479, ASTM A276) for straight fittings and glands	Gland, Body	Tube Socket Weld 1"	3,000	1,935 @ 550°F	
			Automatic Tube Weld 1"	2,200	1,160 @ 550°F	
			Swagelok Tube Fitting 1"	4,700	4,130 @ 550°F	
			Male SAE/MS 1-5/16-12	2,900	2,900 @ 400°F	
			Male NPT 1"	4,700	3,150 @ 450°F with sealant	
			Female NPT 1"	4,400	3,030 @ 450°F with sealant	
	F316 SS (ASTM A182) for shaped fittings	Body	Male NPT 1"	4,700	3,150 @ 450°F with sealant	
			Swagelok Tube Fitting 1"	4,700	4,130 @ 550°F	
			Male SAE/MS 1-5/16-12	2,300	2,300 @ 400°F	



* Maximum temperature of the VCO based on Perfluoroelastomer o-ring material

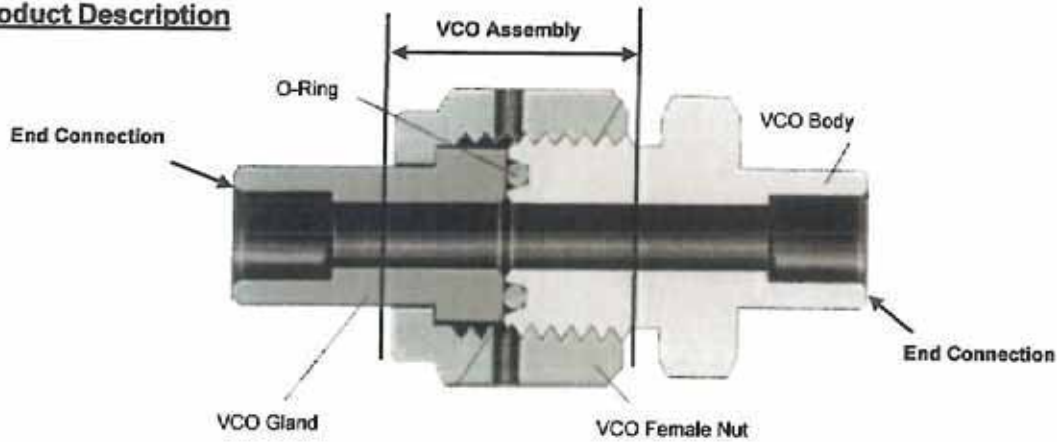

Product Description



Body Configurations

VCO Straights	
VCO Tees	
VCO Elbows	

Product Options

Some of the product options listed below affect the pressure-temperature ratings shown in the Summary Table above, but in all cases the ratings are less than those shown in the above table.

- O-ring Material Options
 - Fluorocarbon FKM
 - Buna N
 - PTFE
 - Perfluoroelastomer
 - Ethylene propylene
- VCO Blind Nuts
- Pressure Bearing Component Material Options (allowable variations of 316 material) that may affect high temperature rating
 - 316L
 - 316LV (VAR)
 - 316LVV (VIMVAR)



Additional options and non-pressure boundary alterations that do not affect pressure-temperature ratings may be made available within the scope of this approval. Examples of these options are:

- VCO Blind Bodies
- Protective Caps
- Caps and Plugs with Lanyards
- Flow Restrictors
- "Bore-through" fitting through holes

Quality System

The Swagelok Company quality system complies with the requirements of ISO 9001:2015. Swagelok Company maintains BSI Certificate of Registration Number FM 01729, which applies to all locations listed on the Certificate.

References

The product catalog does not represent the full scope of the registration but rather details some of the most common options.

- VCO O-Ring Face Seal Fittings Product Catalog MS-01-28, Rev I



Attachment A. Swagelok Manufacturing Locations

This document lists the Swagelok locations where end item or component level manufacturing activities take place.

Swagelok Company 29500 Solon Road Solon, Ohio 44139 USA	Swagelok Company (Falon 1) 348 Bishop Road Highland Heights, Ohio 44143 USA
Swagelok Company (Highland) 318 Bishop Road Highland Heights, Ohio 44143 USA	Swagelok Company (Falon 2) 358 Bishop Road Highland Heights, Ohio 44143 USA
Swagelok Company (OFC) 29495 F.A. Lennon Drive Solon, Ohio 44139 USA	Swagelok Company (HPF) 6050 Cochran Road Solon, Ohio 44139 USA
Swagelok Company (Atlantic) 26651 Curtiss Wright Parkway Willoughby Hills, Ohio 44092 USA	Swagelok Company (Snow Metal) 6060 Cochran Road Solon, Ohio 44139 USA
Swagelok Company (Micro) 26653 Curtiss Wright Parkway Willoughby Hills, Ohio 44092 USA	Swagelok Company (Alfred) 29500 Ambina Drive Solon, Ohio 44139
Swagelok Hose Services Company (SHSC) 29900 Solon Industrial Parkway Solon, Ohio 44139	Swagelok Company (Strongsville) 15400 Foltz Road Strongsville, Ohio 44119
Swagelok (China) Fluid System Technologies Ltd. Changshu Export Process Zone Changshu Economic Development Zone Changshu, Jiangshu 215513 China	Swagelok Limited Ballafletcher Road Tromode IM4 4RA Isle of Man

THIS IS PART OF
GRN 0A22161.5
Technical Standards & Safety Authority
Boilers & Pressure Vessels
Safety Program